

GB Fitting instructions
D Montageanleitung
F Instructions de montage
NL Montage-instructies
I Istruzioni per il montaggio
E Instrucciones de montaje
PT Instruções de Montagem
S Monteringsanvisning
FIN Asennusohje
EST Paigaldusjuhend
LAT Stiprināšanas instrukcija
LIT Pritvirtinimo instrukcijos
PL Instrukcja montażu
RU Инструкции по установке
CZ Návod na montáž

SK Návod na montáž
SLO Navodila za pritrjevanje
HR Uputa za sastavljanje
HU A felszerelés módja
GR Οδηγίες συναρμολόγησης
TR Montaj talimatları
中文 安装说明
日本語 取扱(取付)説明書
한국어 장착 지침
ไทย คำแนะนำการติดตั้ง

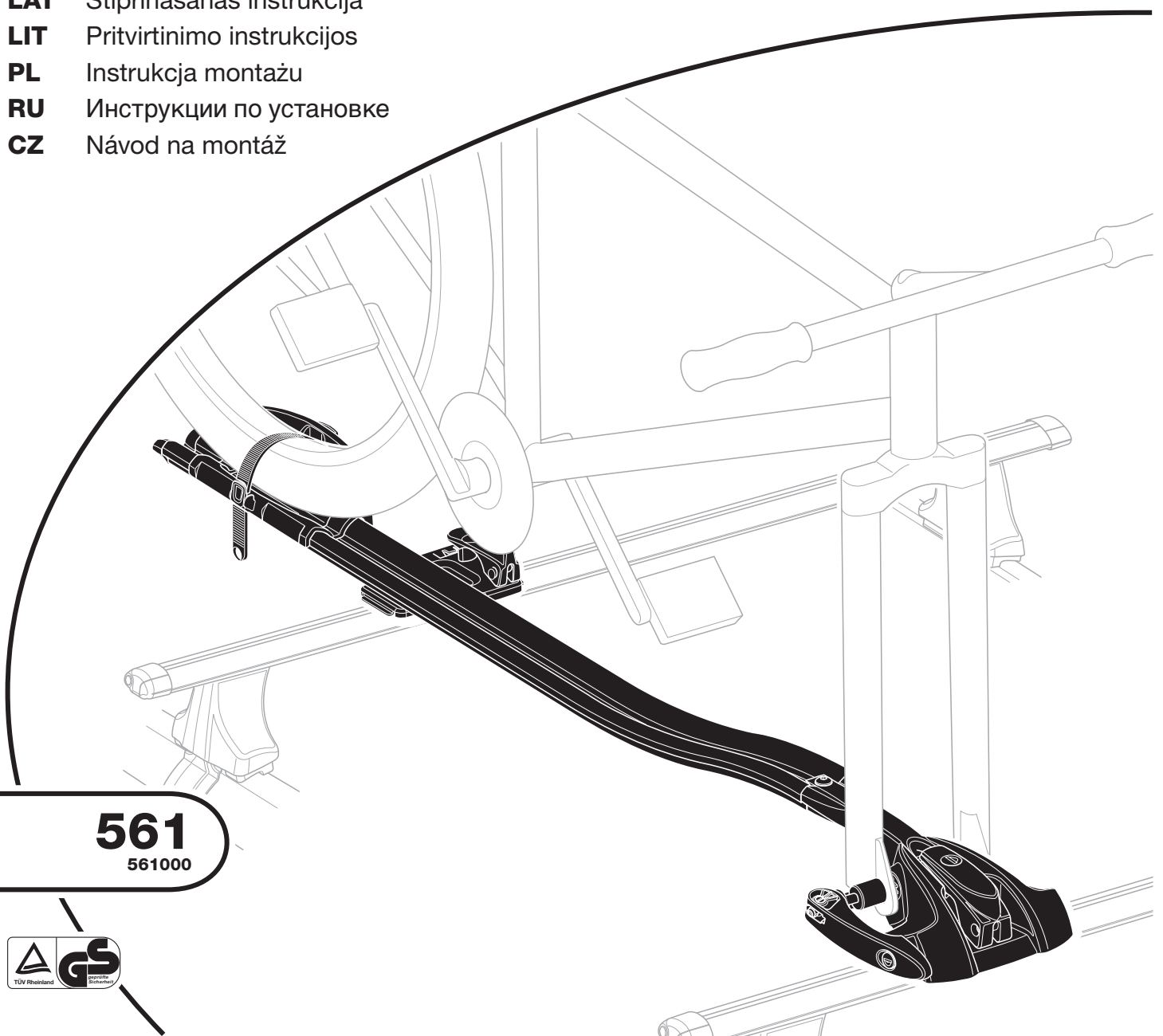

561
561000



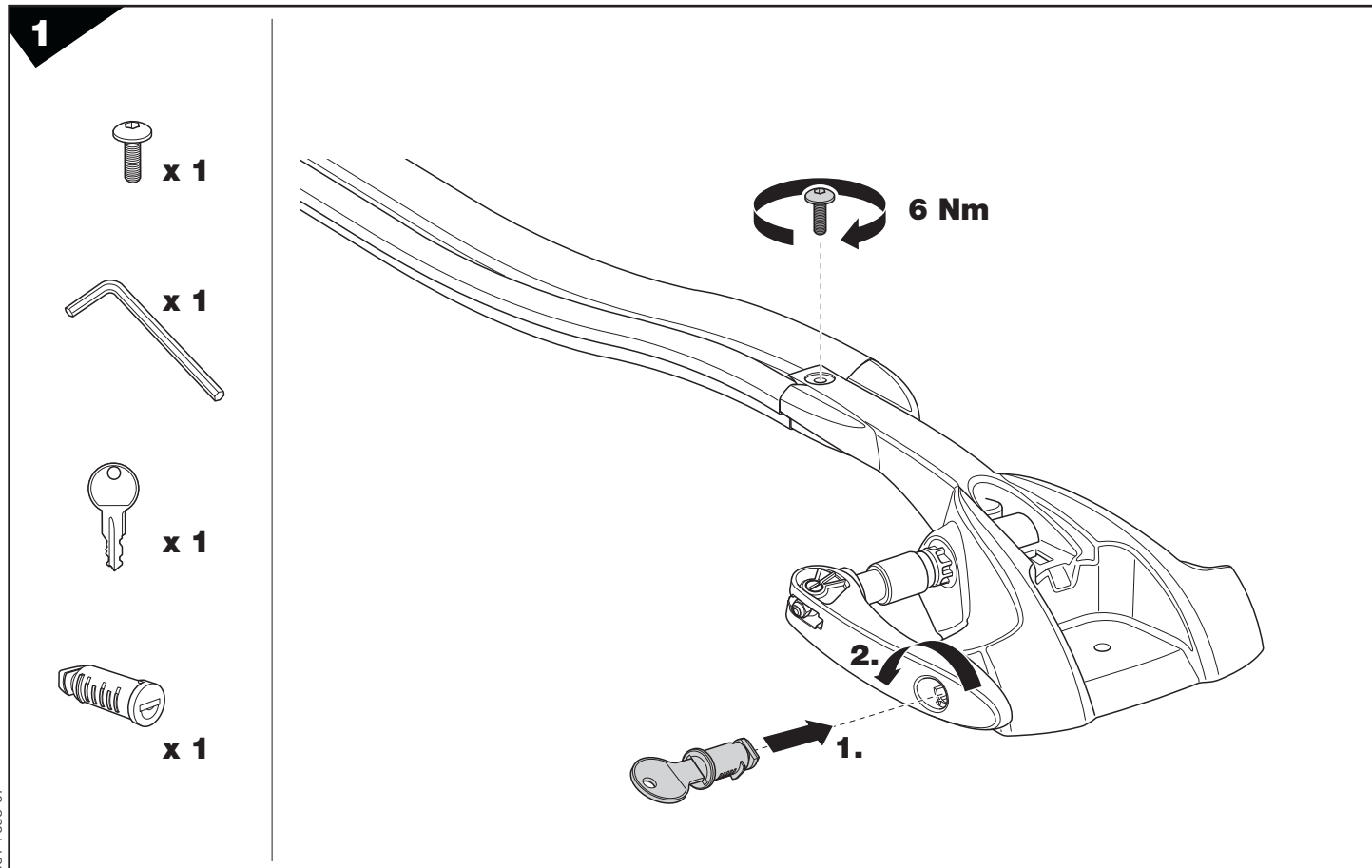
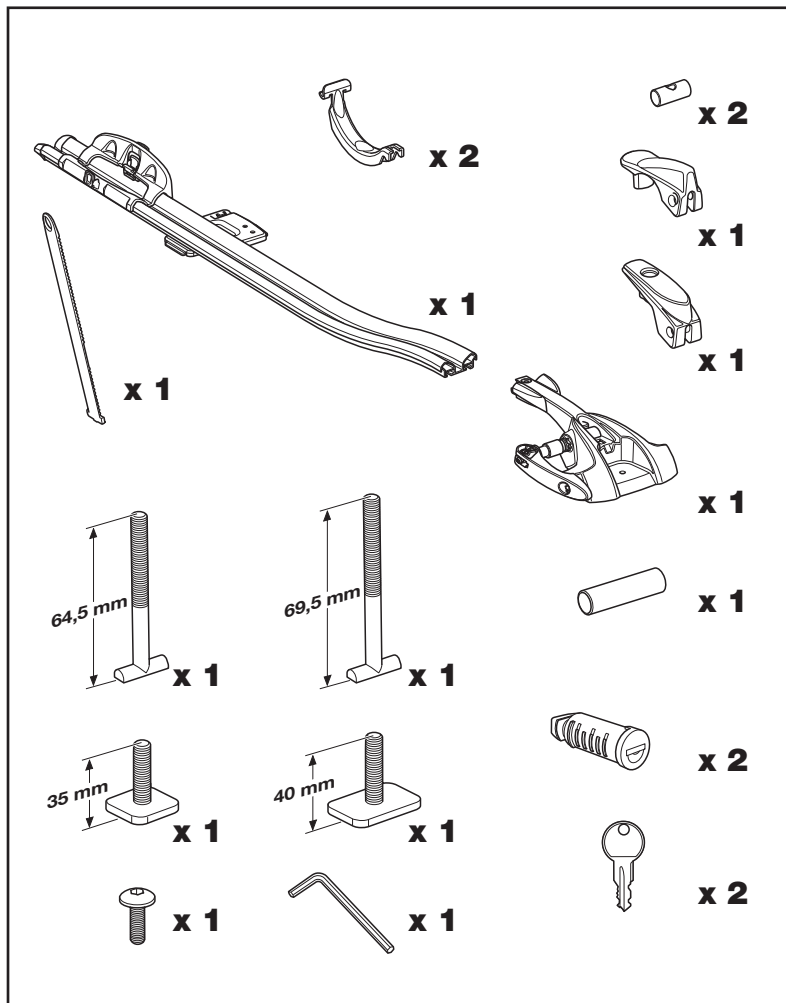
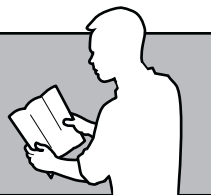

2

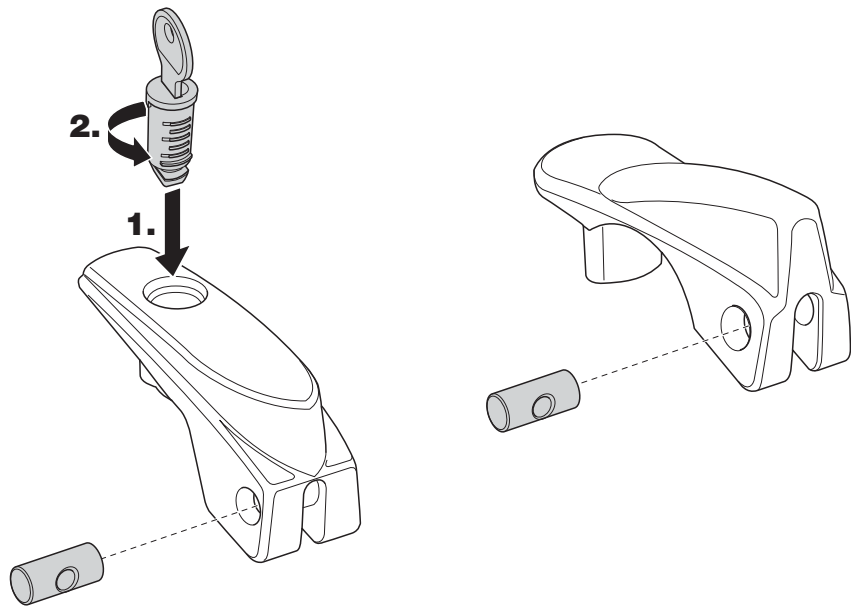
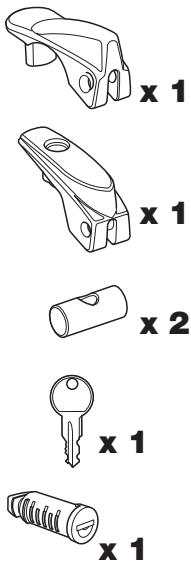

?

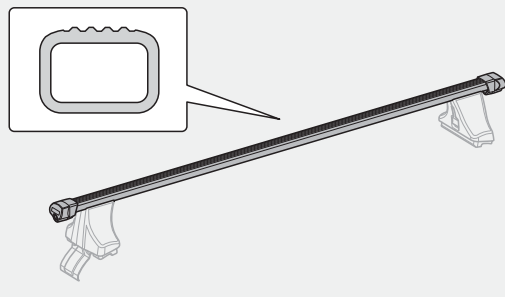
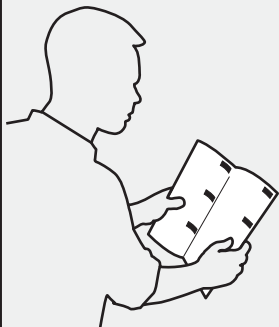

3-5

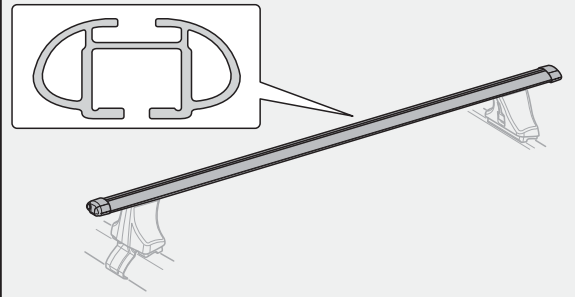
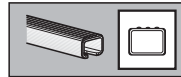

6-7

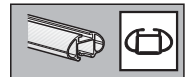

3

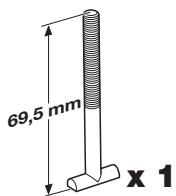
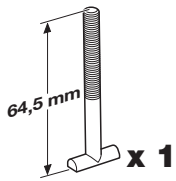

- * GB Only a few turns
- * D Nur wenige Umdrehungen
- * F Quelques tours uniquement
- * NL Slechts enkele slagen
- * I Solo qualche giro
- * E Sólo algunas vueltas
- * PT Noções básicas
- * S Endast några varv
- * FIN Vain muutama kierros
- * EST Ainult mõni pööre
- * LAT Tikai daži apgriezieni
- * LIT Tik keli pasukimai
- * PL Wystarczy kilka obrotów
- * RU Достаточно нескольких оборотов
- * CZ Pouze několik otáček
- * SK Len niekoľko otáčok
- * SLO Le nekaj obratov
- * HR Samo nekoliko okreta

- * HU Csak néhány fordítás
- * GR Μόνο μερικές στροφές
- * TR Yalnız birkaç kez çevirme
- * 中文 只有几个转向
- * 한국어 두 세번만
- * 日本語 数回転のみ
- * ไทย หมุนเพียงไม่กี่รอบ

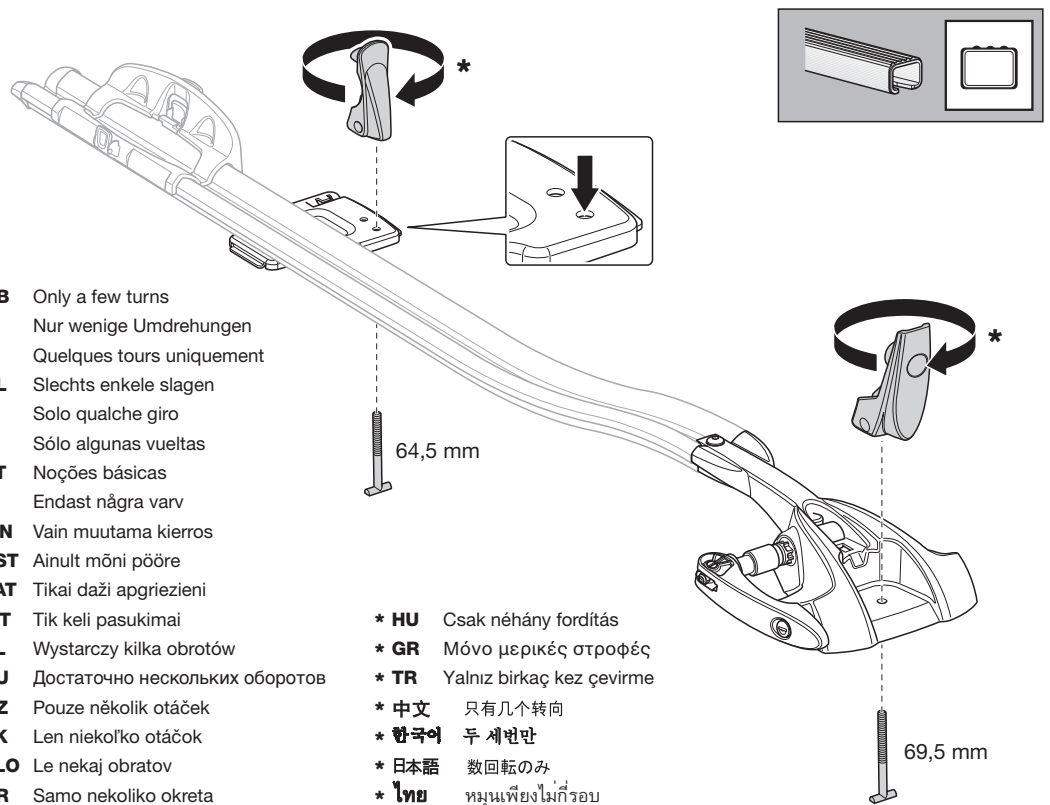

4



x 1

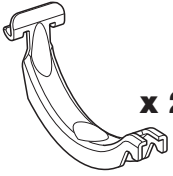

x 2

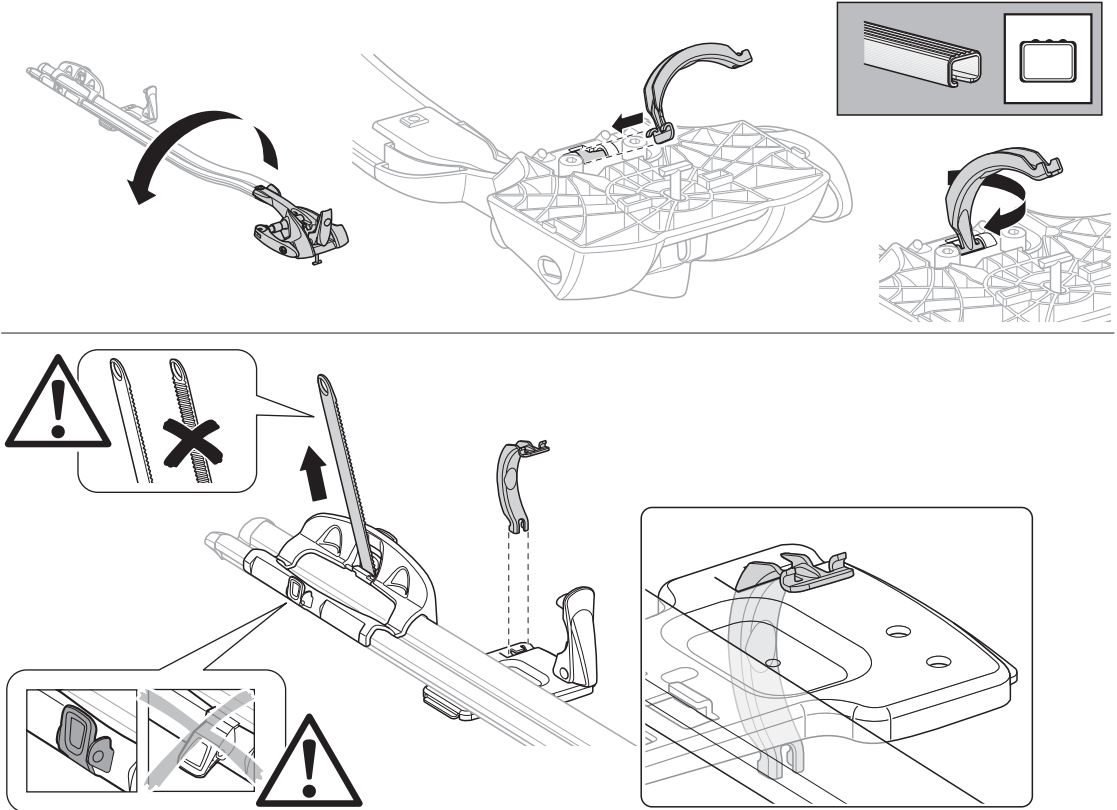

5

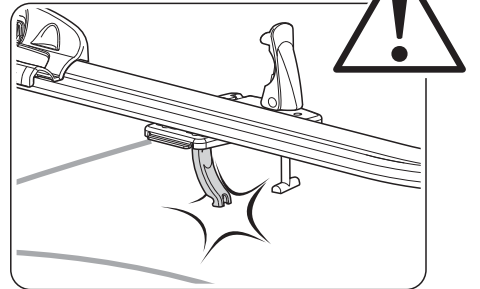
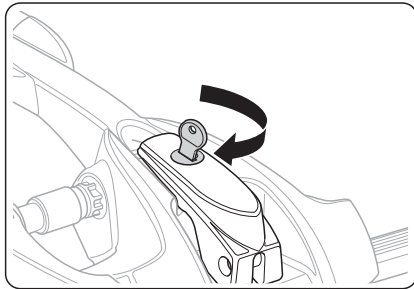
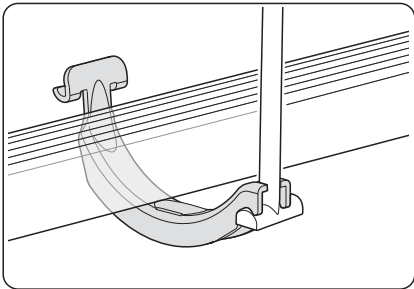
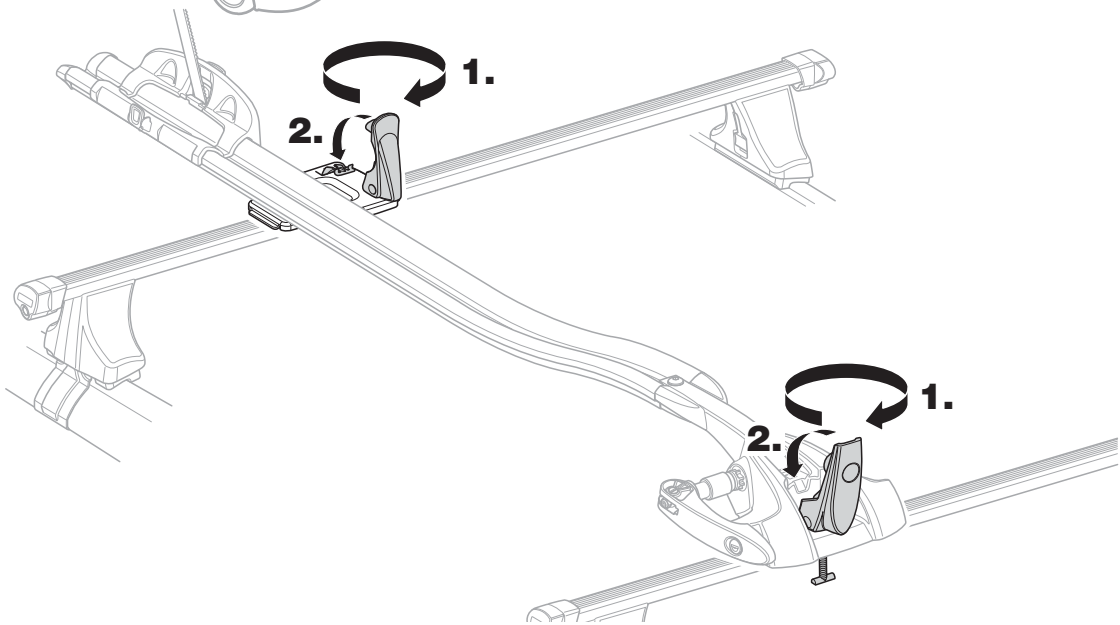
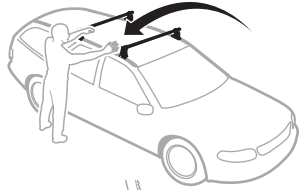

6

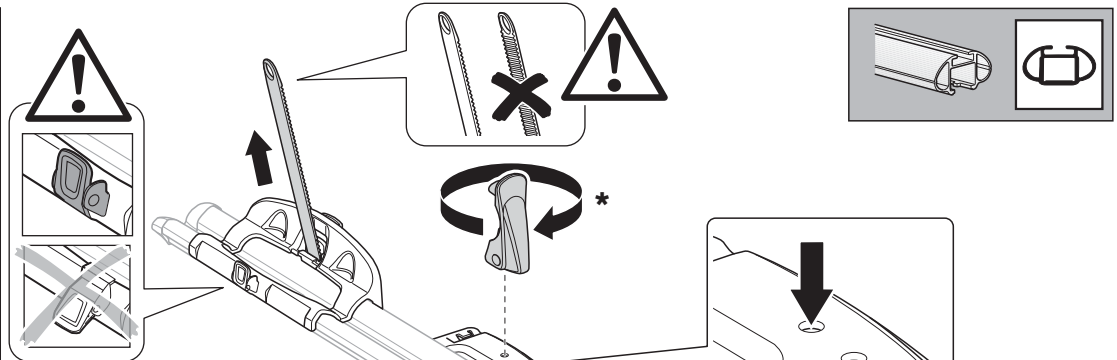
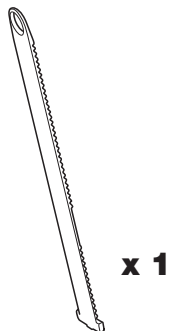
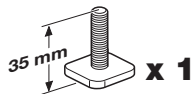
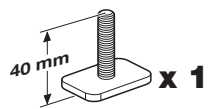

- * GB Only a few turns
- * D Nur wenige Umdrehungen
- * F Quelques tours uniquement
- * NL Slechts enkele slagen
- * I Solo qualche giro
- * E Sólo algunas vueltas
- * PT Noções básicas
- * S Endast några varv
- * FIN Vain muutama kierros
- * EST Ainult mõni pööre
- * LAT Tikai dažī apgriezieni
- * LIT Tik keli pasukimai
- * PL Wystarczy kilka obrotów
- * RU Достаточно нескольких оборотов
- * CZ Pouze několik otáček
- * SK Len niekoľko otáčok
- * SLO Le nekaj obratov
- * HR Samo nekoliko okreta

- * HU Csak néhány fordítás
- * GR Μόνο μερικές στροφές
- * TR Yalnız birkaç kez çevirme
- * 中文 只有几个转向
- * 한국어 두 세번만
- * 日本語 数回転のみ
- * ไทย หมุนเพียงไม่กี่รอบ

7

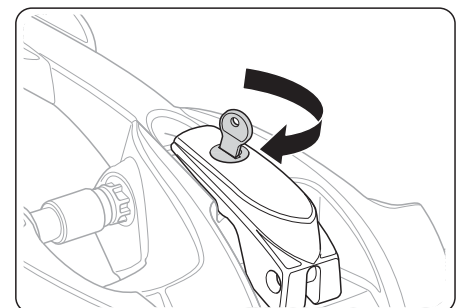
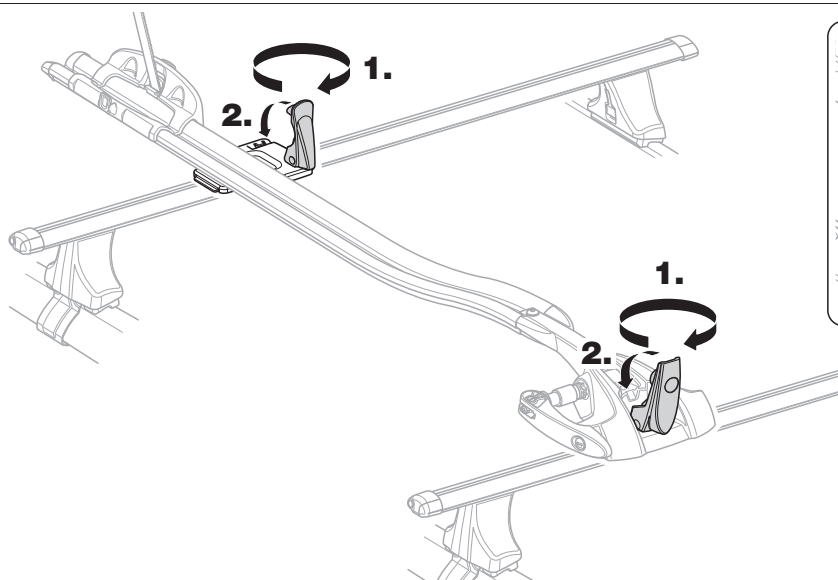
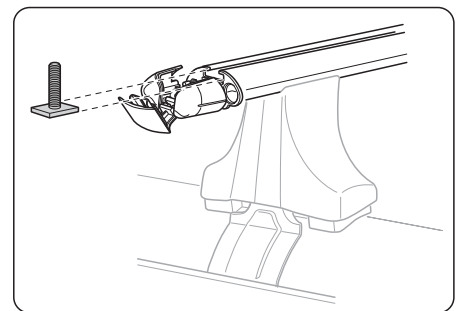
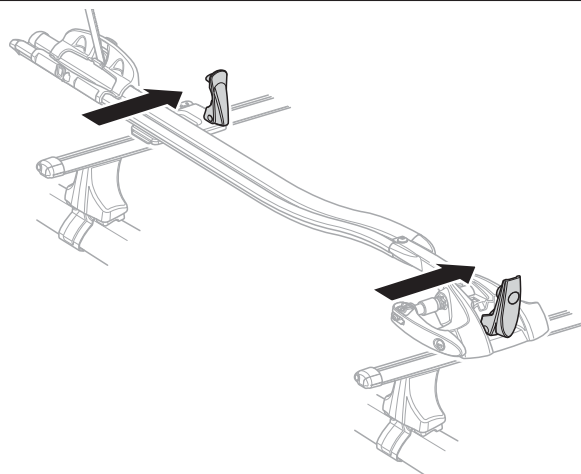
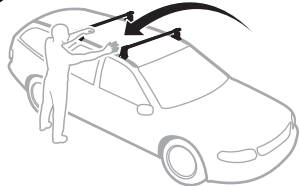

8

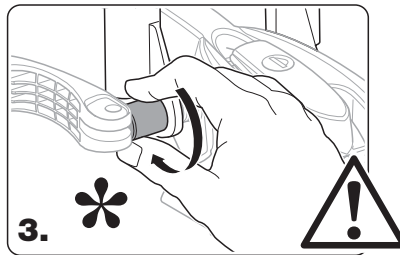
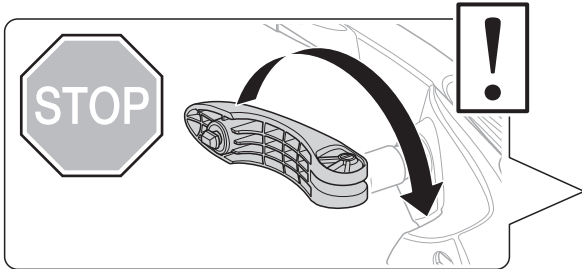
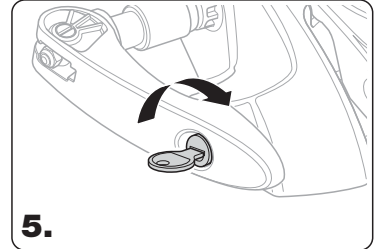
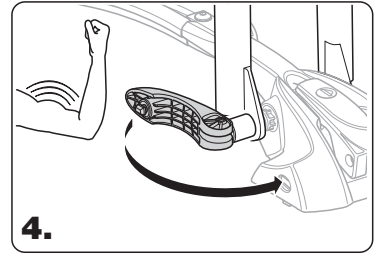
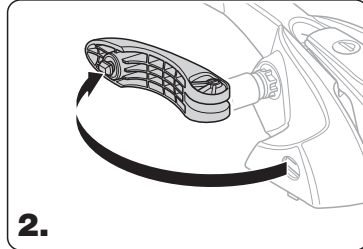
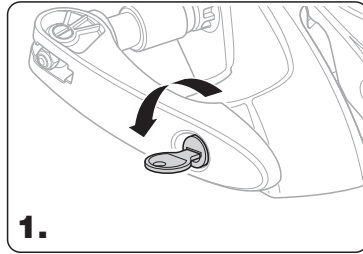
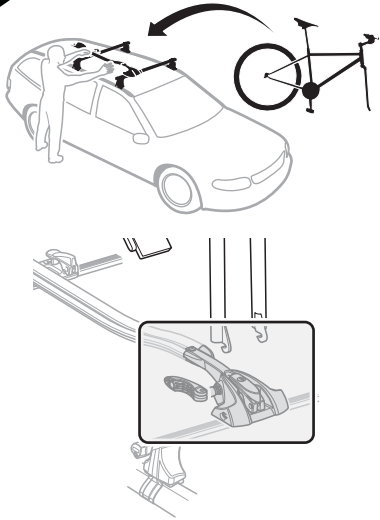

9

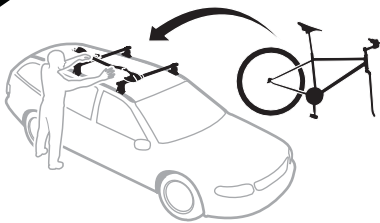

Fit Tips!

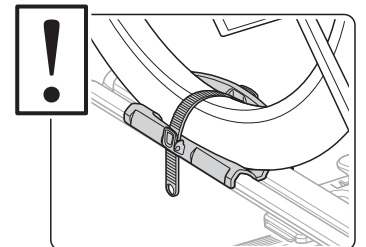
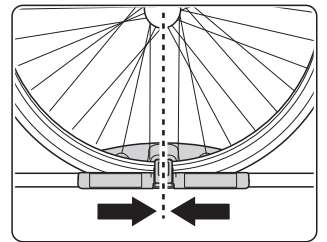
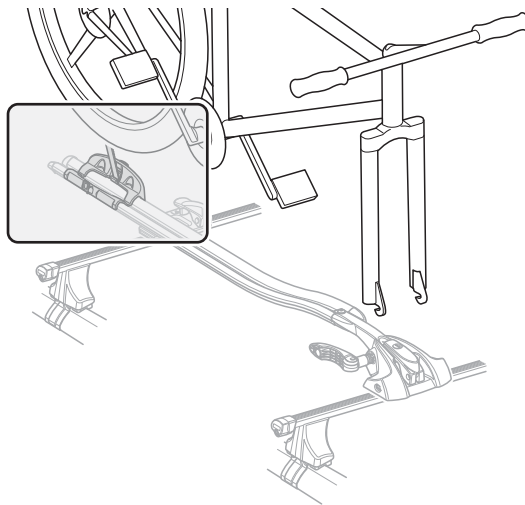
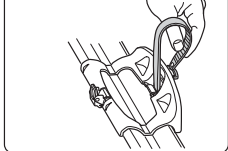

10

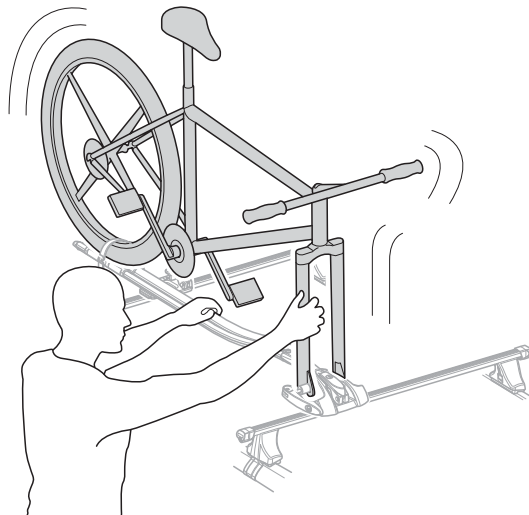
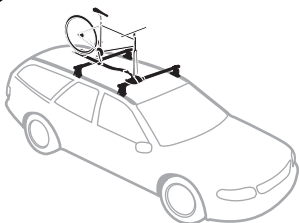

GB Left-hand fitting
D Montage links
F Montage côté gauche
NL Montage aan de linker kant
I Montaggio a sinistra
E Montaje a izquierda
PT Montagem do lado esquerdo

S Vänstermonterad
FIN Asennus vasemmalle
EST Vasakpoolne kinnitamine
LAT Kreisais stiprinājums
LIT Kairysis pritvirtinimas
PL Montaż z lewej
RU Установка на левую сторону

CZ Montáž z levé strany
SK Montáž na ľavej strane
SLO Pritrjevanje z leve strani
HR Montaža s lijeve strane
HU Bal oldalról szerelhető
GR Αριστερόστροφη τοποθέτηση

TR Sol elle montaj
中文 从左侧安装
日本語 左側の取り付け
한국어 왼손잡이용 장착
ไทย การติดตั้งสำหรับด้านซ้าย

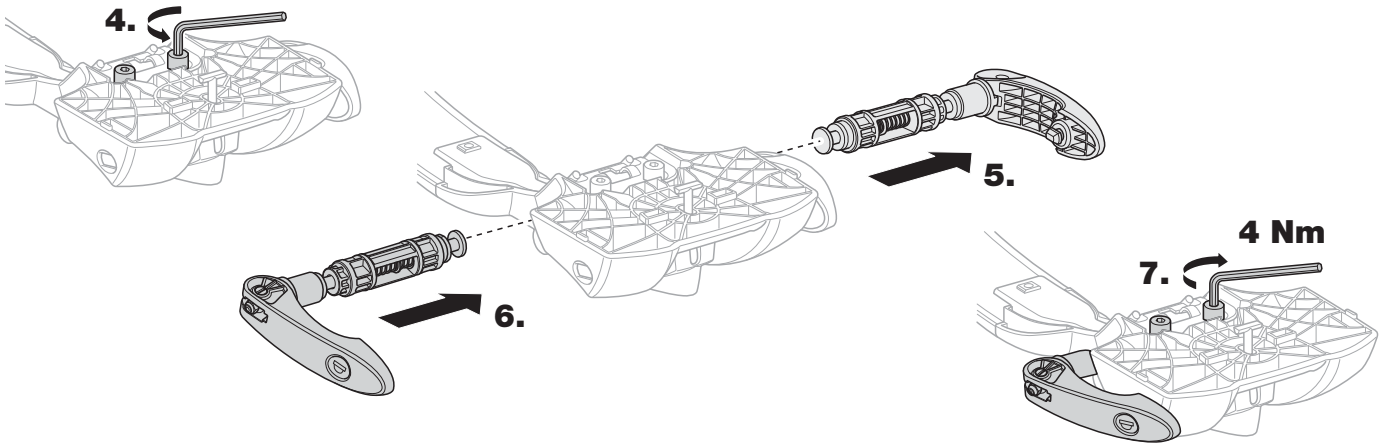
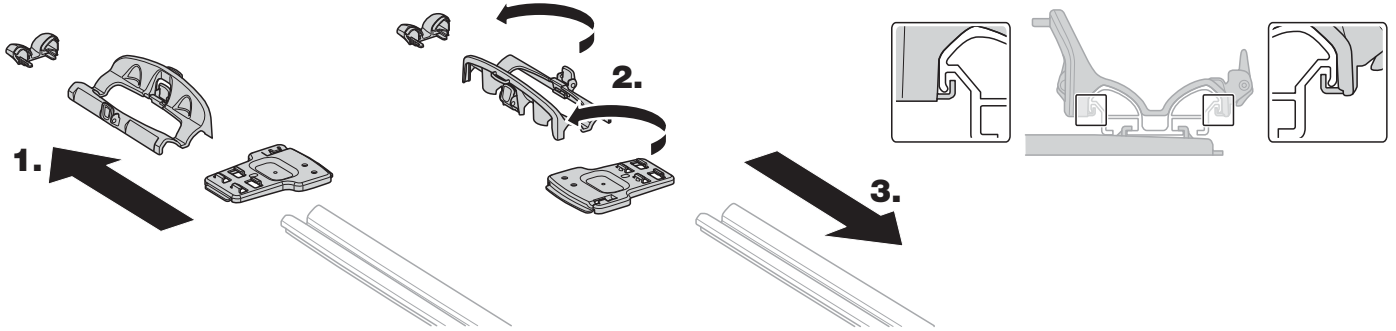
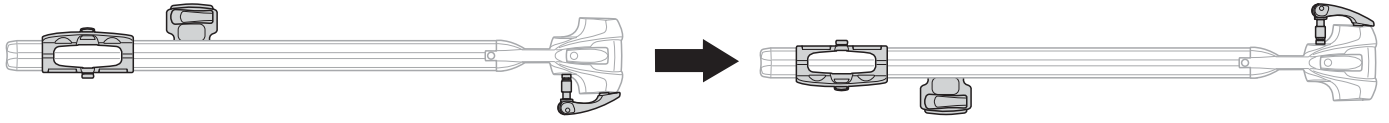

GB Adapter for Ø20 axle
D Adapter f. Tragachse m. Ø 20
F Adaptateur pour arbre de Ø 20 mm
NL Verloopstu voor Ø20-as
I Adattatore per assale Ø20
E Adaptador para eje de Ø20 mm
PT Adaptador para eixo de Ø20 mm
S Adapter för Ø20 mm axel
FIN Sovitin Ø 20 mm akselille

EST Adapter Ø20 teljele
LAT Ø20 mm ass adapteris
LIT Adapteris Ø20 mm ašiai
PL Złączka dla osi Ø20
RU Переходник для оси Ø20
CZ Adaptér pro osu Ø 20 mm
SK Adaptér na os Ø20 mm.
SLO Adapter za os Ø 20
HR Adapter za os od Ø20 mm

HU Adapter Ø20 mm-es tengelyhez
GR Προσαρμογέας άξονα Ø20 mm
TR Ø20 mm aks adaptörü
中文 Ø20 车轴适配器
日本語 直径 20mm アクセル用アダプター
한국어 Ø20 축용 어댑터
ไทย ตัวปรับโตด Ø20 มม.

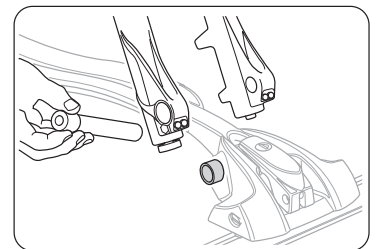
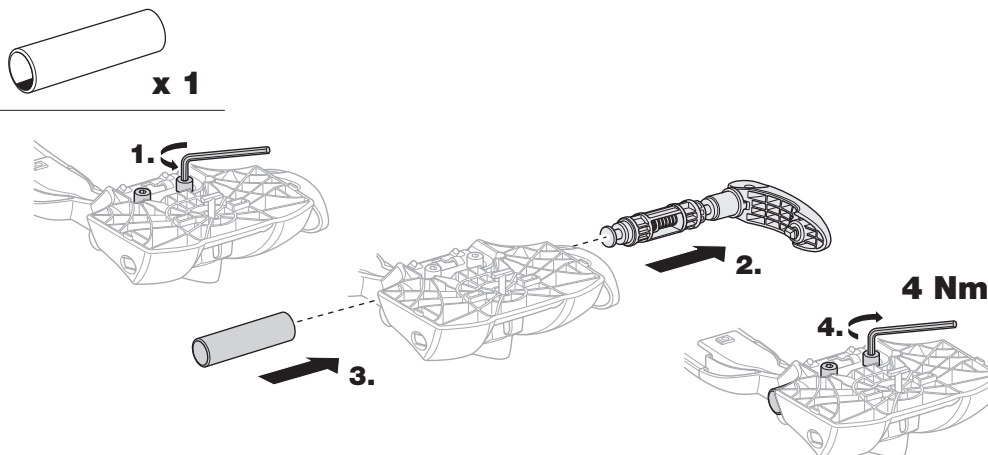

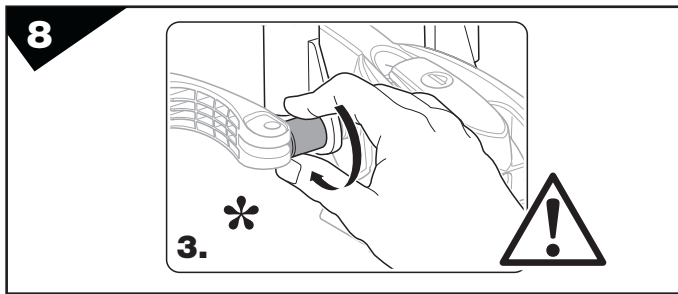

GB PLEASE NOTE: When the bicycle is not attached the clamping sleeve (Figure 8:3) can lose its clamping force. Therefore step 8 must always be carried out when the bicycle is attached.

D BEACHTEN SIE: Wenn das Fahrrad nicht befestigt ist, kann die Spannhülse (Abb. 8:3) ihre Spannkraft verlieren. Führen Sie daher bei der Befestigung des Fahrrades Schritt 8 immer ordnungsgemäß durch.

F N.B.È: Quand le vélo n'est pas fixé, le manchon de blocage peut perdre de sa force (Figure 8:3). Par conséquent, l'étape 8 doit toujours être effectuée alors que le vélo est fixé.

NL LET OP: Als de fiets niet is bevestigd, kan de klembus (Figuur 8:3) zijn klemkracht verliezen. Daarom moet stap 8 altijd worden uitgevoerd als de fiets wordt bevestigd.

I NOTA: Quando non è fissata al maniccotto di bloccaggio (Figura 8:3), la bicicletta si può allentare. Pertanto, in sede di fissaggio della bicicletta deve sempre essere completato il punto 8.

E ATENCIÓN: Cuando no hay una bicicleta colocada en el portabicicletas, la manilla de ajuste (imagen 8:3) puede perder capacidad de sujeción. Por ello, cuando se coloque la bicicleta, siempre debe llevarse a cabo lo indicado en el paso 8.

PT OBSERVAR: Quando a bicicleta não está afixada, a luva de aperto (Fig. 8:3) pode perder sua força. Desta forma, a etapa 8 deve ser sempre executada quando a bicicleta estiver afixada.

S OBSERVERA: När cykeln inte är monterad kan spännhylsan (bild 8:3) förlora sin spännkraft. Därför måste alltid steg 8 utföras när cykeln monteras.

FIN HUOMIO: Kun pyörää ei ole kiinnitetty, kirstysmuhvin (kuva 8:3) kirstysvoima voi heiketä. Siksi vaihe 8 on suoritettava aina, kun pyörä on kiinnitetty.

EST NB! Kui jalgratas ei ole kinnitatud, võib kinnituspuks (joonis 8.3) oma kinnitusjõu kaotada. Seega tuleb jalgratta kinnitamisel järgida alati punktis 8 kirjeldatud tegevusi.

LAT Piezīme. Ja velosipēds nav atbilstoši pievienots, fiksēšanas uzdeva (8:3 attēls) var nenofiksēties. Tādēļ, nostiprinot velosipēdu, vienmēr jāievēro 8. darbībā sniegtās norādes.

LIT PRAŠOME ATKREIPTI DĖMESĮ: jei nepritvirtintas dviratis, spaudžiamoji mova (8:3 pav.) gali nebespausti. Dėl šios priežasties, kai pritvirtintas dviratis, būtina atlikti 8-ą etapą.

PL UWAGA: Jeśli rower nie jest przymocowany do bagażnika, ramię zatrzaskowe (rysunek 8:3) może utracić siłę zatrzaskiwania. Dlatego zawsze, gdy rower jest przymocowany, należy wykonać krok 8.

RU ВНИМАНИЕ! Если велосипед не прикреплен с помощью крепежной втулки (рисунок 8:3), зажимное усилие может ослабиться. Поэтому при креплении велосипеда всегда следует выполнять шаг 8.

CZ POZNÁMKA: Pokud není jízdní kolo připojeno, stahovací objímka (obrázek 8:3) může ztratit svěrnou sílu. Proto, pokud je jízdní kolo připojeno, musí být vždy proveden krok 8.

SK POZNÁMKA: Ak nie je bicykel pripojený, sťahovacia objímka (obrázok 8:3) môže stratiť silu zvierania. Preto je v prípade, že je bicykel pripojený, potrebné vždy vykonať krok 8.

SLO POMEMBNO: Kadar na nosilcu ni kolesa, lahko ročica za vpenjanje (Slika 8: 3) izgubi vpenjalno silo. Zato mora biti ob vsakem vpenjanju kolesa izveden 8. korak.

HR NAPOMENA: Kada bicikl nije pričvršćen, konektor za učvršćivanje može (Figure 8:3) popustiti. Stoga je uvijek kada je pričvršćen bicikl potrebno postupiti kao što je opisano u 8. koraku.

HU FONTOS: Ha a kerékpár nincsen rögzítve, a szorítóhüvely (8.3. ábra) elvesztheti szorítóerejét. Emiatt a kerékpár rögzítésekor a 8. lépést mindig el kell végezni.

GR ΠΑΡΑΚΑΛΟΥΜΕ ΣΗΜΕΙΩΣΤΕ: Όταν το ποδήλατο δεν είναι προσαρτημένο με τον σφιγκτήρα, (Εικόνα 8:3) αυτός μπορεί να χάσει τη δύναμη σύσφιξης. Ως εκ τούτου, το βήμα 8 θα πρέπει πάντα να πραγματοποιείται όταν το ποδήλατο είναι προσαρτημένο.

TR LÜTFEN DİKKAT EDİN: Bisiklet bağlı değilse, sıkıştırma manşonu (Şekil 8:3) sıkıştırma gücünü kaybedebilir. Bu yüzden bisiklet bağlıyken daima 8. adım uygulanmalıdır.

中文 注意: 自転車未装着時、クランプスリーブ(図8:3)のクランプ力が低下します。そのため、自転車を装着するときは、ステップ8を必ず行ってください。

日本語 请注意: 未缚系自行车时, 夹紧连接轴套(图 8:3) 会失去夹紧力。因此, 在缚系自行车时一定要执行步骤 8。

한국어 참고: 자전거에 압착 슬리브(그림 8:3)가 부착되어 있지 않으면 압착력이 줄어들 수 있습니다. 따라서 자전거를 부착할 때는 반드시 8 단계를 수행해야 합니다.

ไทย โปรดสังเกต: เมื่อจักรยานไม่ได้ติดเข้ากับแขนยึด (รูปที่ 8:3) อาจทำให้สูญเสียแรงยึดได้ ดังนั้นขั้นตอนที่ 8 ต้องดำเนินการเมื่อมีการยึดจักรยานอยู่เท่านั้น

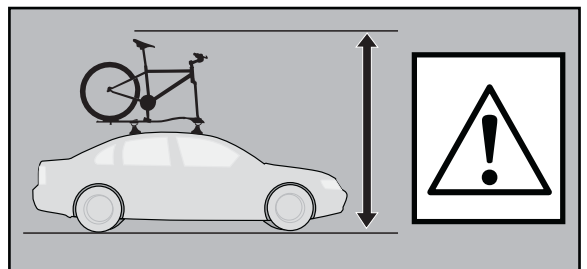
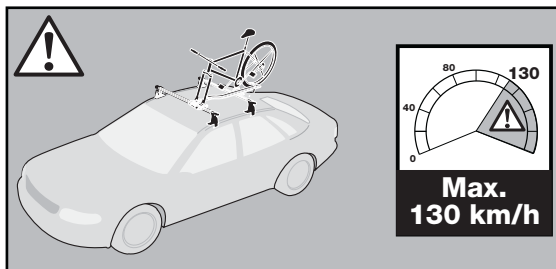
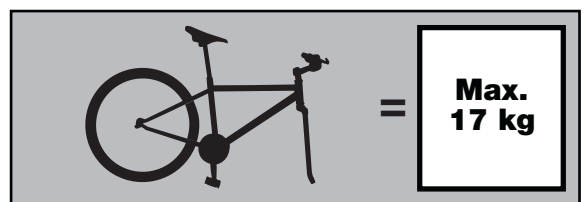
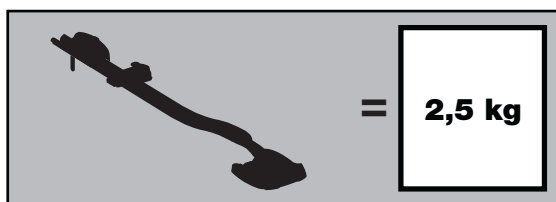
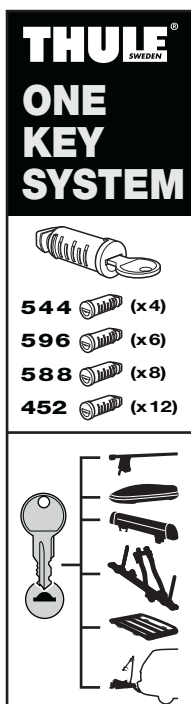

THULE[®]
SWEDEN

Box 69, 330 33 Hillerstorp, SWEDEN
www.thule.com